

SEPARABLE TEE CONNECTORS (FMCTs-600/1250)

CHARACTERISTICS

For polymeric cable up to 24kV

Non-loadbreak operation

600 series for 1250A (with clamping screw)

The Prysmian range of FORMFIT[®] Separable Connectors has a wide range of applications including connection to transformers, switchgear units, motors etc.

Suitable for indoor and outdoor installations, the connector is entirely protected by a watertight conductive envelope connected to earth.

The connectors are rated for continuous operation at 1250 Amp rms, with 1800 Amp rms overload (8 hours per 24 hours).

FORMFIT[®] 600/1250 series of separable connectors are suitable for use with a wide range of polymeric medium voltage cables, including:

- Single core polymeric insulation (PE, XLPE, EPR etc).
- Copper or aluminium conductors (50-630mm²).
- Semi-conducting screen either extruded or taped.
- Metallic screen, wire or polylam type.
- Insulation voltage up to 24kV (Um).

FEATURES & BENEFITS

- No need for special tools, heating, taping or filling
- Vertical, angled or inverted position
- No minimum distance between phases
- Energising may take place immediately after the connector is plugged to its individual bushing, dead end plug etc.
- Connectors packed separately



DESCRIPTION

1. Clamping screw

Copper component, threaded at both ends, for attachment of the mating items: bushing, insulating plug, accessories. A uniform contact pressure is maintained for any combination.

2. Conductor contact

The barrel side, sized for the conductor, is of a compression type. Contact with the clamping screw is through the spade.

3. Semi-conducting inner screen

Insert of moulded semi-conducting EPDM, enclosing the connecting components, so that ionisation of any air remaining trapped is prevented.

4. Semi-conducting outer envelope

Jacket made of semi-conducting EPDM. Its design provides relief of electrical stress as does a cable screen. Its connection to the cable screen ensures that the assembly is maintained at earth potential.

5. Insulating body

Moulded from insulating EPDM for integral reconstitution of insulation. It maintains a uniform contact pressure on the cable insulation and the interface of the mating items.

6. Reducer

Composite EPDM moulding allowing connector adaptation to cables of different cross-sections and voltages.

7. Insulating plug

Epoxy component which has a threaded metal insert to accept the clamping screw.

8. Test point

Metallic insert with a hexagonal head. A capacitive voltage divider provides a means of checking that the item is not live before disconnection.

9. Cap

Moulded semi-conducting EPDM part, protects and earths the test point during normal use.

10. Earth cover

Made of moulded EPDM, ensures watertight protection of the earthing device.

11. Earthing Eye

Eye provided for connection of the outer envelope to the cable screen.

FMCTs-600/1250 Separable Tee Connector

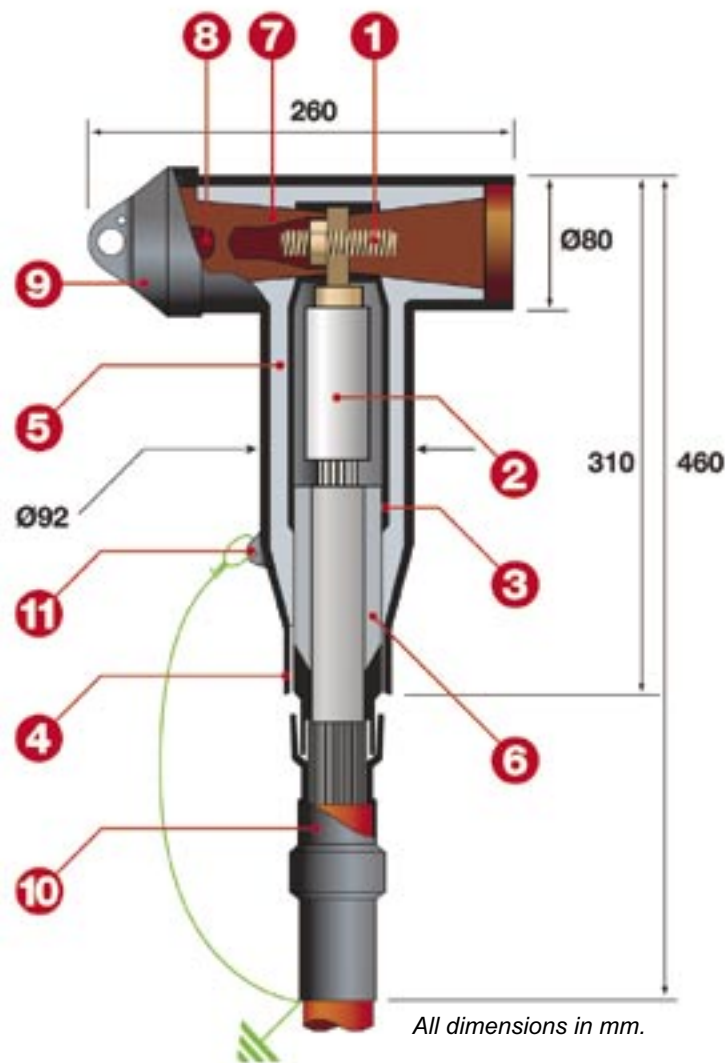

SELECTION GUIDE

1. Select from **TABLE A** on the right the kit model corresponding to the diameter over the insulation table.

2. Specify insulation voltage U_m in kV:
12 - 17 - 24

3. Select from the **TABLE B** (bottom right) the earthing device to suit the cable

4. Select the model of connection end-fitting⁽¹⁾ according to:

■ Conductor material **C: Copper**
A: Aluminium

■ Conductor Size **In mm²**

⁽¹⁾ Can be crimped or indented by usual tools

EXAMPLE ORDER

Example #1

Cable 22kV, 300mm², insulation diameter 33.2mm, aluminium conductor, copper wire screen:

FMCTs-600/1250-J-24-T3-A300

TABLE A

Separable Tee Connector					
Diameter over insulation mm		Kit Reference	Conductor size mm ² (for guidance only) Highest Voltage		
MIN	MAX		12kV	17.5kV	24kV
19.7	23.6	FMCTs-600/1250-A	120	95	50
21.0	24.9	FMCTs-600/1250-B	150	120	70
22.2	26.2	FMCTs-600/1250-C		150	95
23.3	27.5	FMCTs-600/1250-D	185		120
24.9	28.8	FMCTs-600/1250-E	240	185	150
26.4	30.3	FMCTs-600/1250-F			
27.8	31.8	FMCTs-600/1250-G	300	240	185
29.5	33.5	FMCTs-600/1250-H		300	240
31.0	35.0	FMCTs-600/1250-J	400		300
32.6	36.6	FMCTs-600/1250-K		400	
34.4	38.6	FMCTs-600/1250-L	500		400
37.7	42.0	FMCTs-600/1250-M	630	500	
38.9	43.4	FMCTs-600/1250-N			500
40.0	44.5	FMCTs-600/1250-P		630	
42.3	47.1	FMCTs-600/1250-Q			630

TABLE B

Earthing Device Reference	Type of Metallic Screen of Cable
T1	polylam
T2	copper tapes
T3	copper wires

FMCTs-600/1250

Separable Tee Connector

Overall dimensions (mounted on bushing)

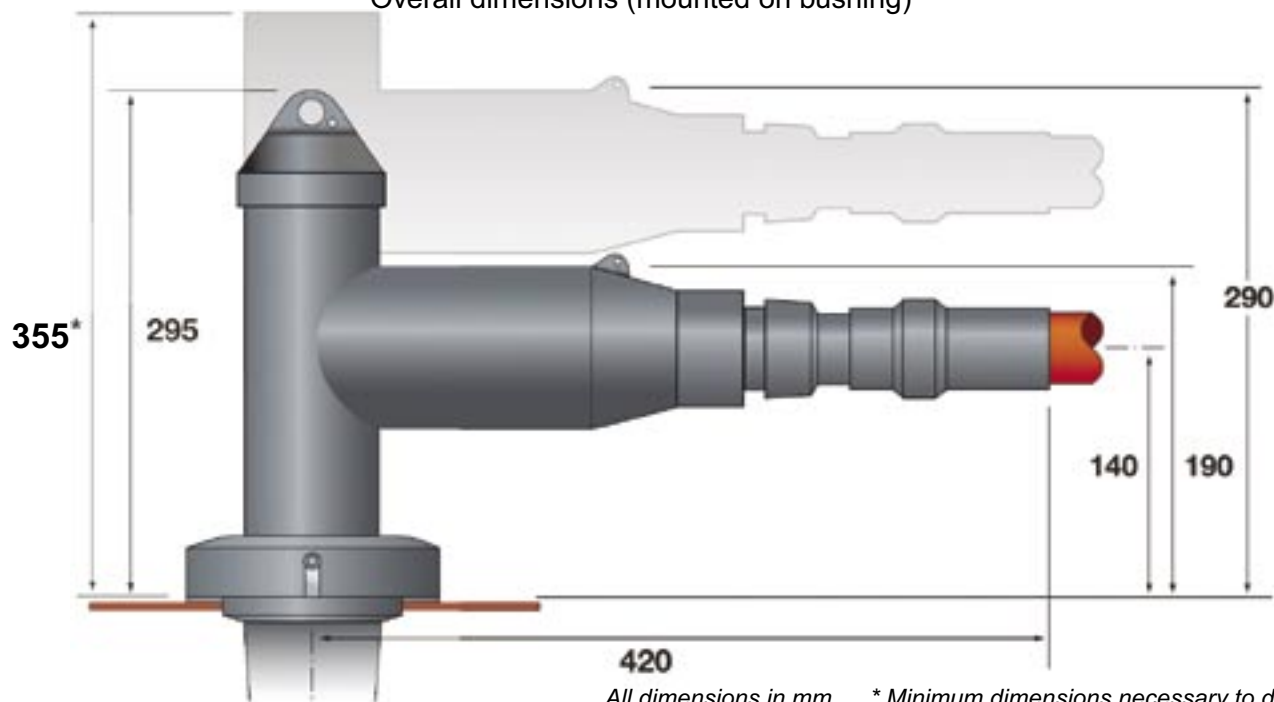

All dimensions in mm. * Minimum dimensions necessary to disconnect.



Formerly Pirelli Cables

ACCESSORIES FOR 400A SEPARABLE CONNECTORS**FMPCs-400** Straight Connecting Plug

- Epoxy resin moulding over a copper rod for connecting two separable tee connectors (FMCTs 600/1250), in combinations such as disconnectable cable joint and tee off dual cable supply.
- Connection to rod by the clamping screws of the connectors. Screening of the connecting components. Integral reconstitution of insulation and protection continuity.
- Operated when de-energised.
- References: **12kV - FMPCs-600-12**
24kV - FMPCs-600-24
- Packing: Single Unit

FMPI-400 Insulating Plug

- Epoxy resin moulding which provides a dead-end facility for separable tee connectors
- Operated when de-energised.
- Capacity voltage divider included in casting, protected by a cap of semi-conducting EPDM.
- References: **12kV - FMPI-600-12**
24kV - FMPI-600-24
- Packing: Single Unit

FMPR-400 Reducing Plug

- Epoxy resin moulding which allows a separable tee connector FMCTs 600/1250 to accept connectors of the 250 A series
- Connection to separable tee connector by clamping screw.
- Operated when de-energised.
- References: **12kV - FMPR-400-12**
24kV - FMPR-400-24
- Packing: Single Unit

STANDARDS

Master specification PRYSMIAN SP.5 Generally meet the requirements of IEC 540 - EDF HN 52-S-61 - ANSI/IEE 386 - NF C 33-051 - VDE 0278 - IEC 71.

QUALITY ASSURANCE

Certified to ISO 9001



Formerly Pirelli Cables

Commercial Enquiries

Tel +44 (0) 845 767 8345,
Fax +44 (0) 23 8029 5465

OTHER PRODUCTS

We also supply other accessories from the 600/1250 series
Details available on request

www.prysmian.co.uk

sepsFMCTs600_1250uk/02/05

Prysmian Cables & Systems Limited

Components Unit, Oak Road, Wrexham Industrial Estate, Wrexham, LL13 9PH, UK