

Industrial Gland Kits

BW LSOH Brass Gland Kit LSF - BW Series



Application

- > Indoor type for SWA cable

Features & Benefits

- > Brass indoor gland and accessories
- > For galvanized-steel single-wire armour plastic or rubber sheathed cables
- > For use in dry, dust free, situations
- > Provides mechanical cable retention and electrical continuity via armour locking mechanism
- > Kit comprises:
 - BW Gland
 - Brass earth tag
 - Brass locknut
 - LSF shroud
- > 2 per kit up to and including 25mm size

Technical Data

- > To BS6121-1
- > CuZn39Pb3 extruded brass alloy used for guaranteed strength and performance
- > Service temperature range -20°C to +90°C
- > Zero Halogen silicone shroud - LUL approved



BW LSOH Brass Gland Kit LSF - BW Series

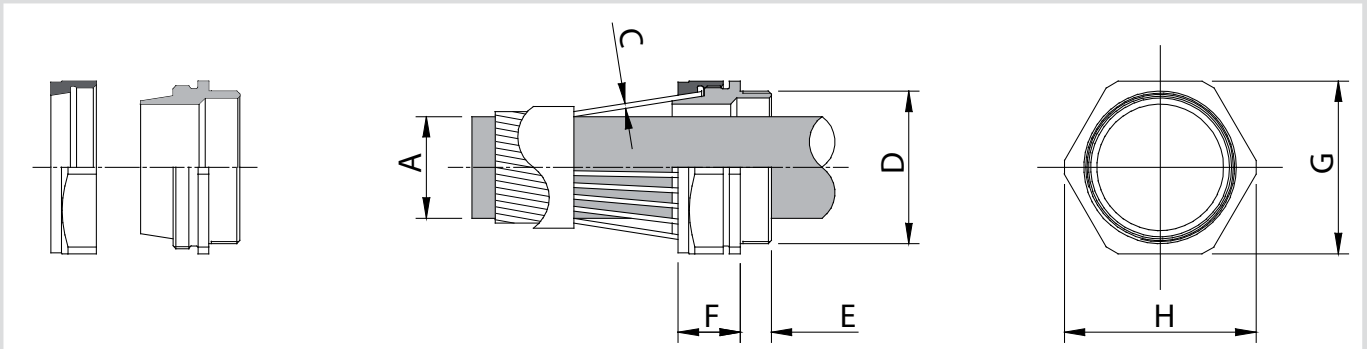

Gland Details

Cable Dimensions mm		Kit Reference			Gland Dimensions mm				
Under Armour Diameter A Max	Armour Wire Diameter C	Size	Design Number	Items Per Kit	Entry Thread		Approx. Length From Shoulder F	Hexagon Size	
					Size D	Length E		Across Flats G	Across Corners H
11.6	0.9	20S	LSF20SBW	2	M20 × 1.5	10	24	22.0	24.9
13.9	0.9 / 1.25	20	LSF20BW	2	M20 × 1.5	10	25	27.0	30.5
19.9	1.25 / 1.6	25	LSF25BW	2	M25 × 1.5	10	26	37.6	42.2
26.2	1.6 / 2.0	32	LSF32BW	1	M32 × 1.5	10	28	47.3	53.6
32.1	1.6 / 2.0	40	LSF40BW	1	M40 × 1.5	15	25	50.0	57.0
44.0	2.0 / 2.5	50	LSF50BW	1	M50 × 1.5	15	36	70.1	77.2
55.9	2.5	63	LSF63BW	1	M63 × 1.5	15	30	80.0	87.4
61.9	2.5	75S	LSF75SBW	1	M75 × 1.5	15	40	85.0	95.0
67.9	2.5	75	LSF75BW	1	M75 × 1.5	15	40	98.8	109.2